

GLOBE VALVE WITH FLOW CONTROL

Клапан с регулировкой расхода

PN16

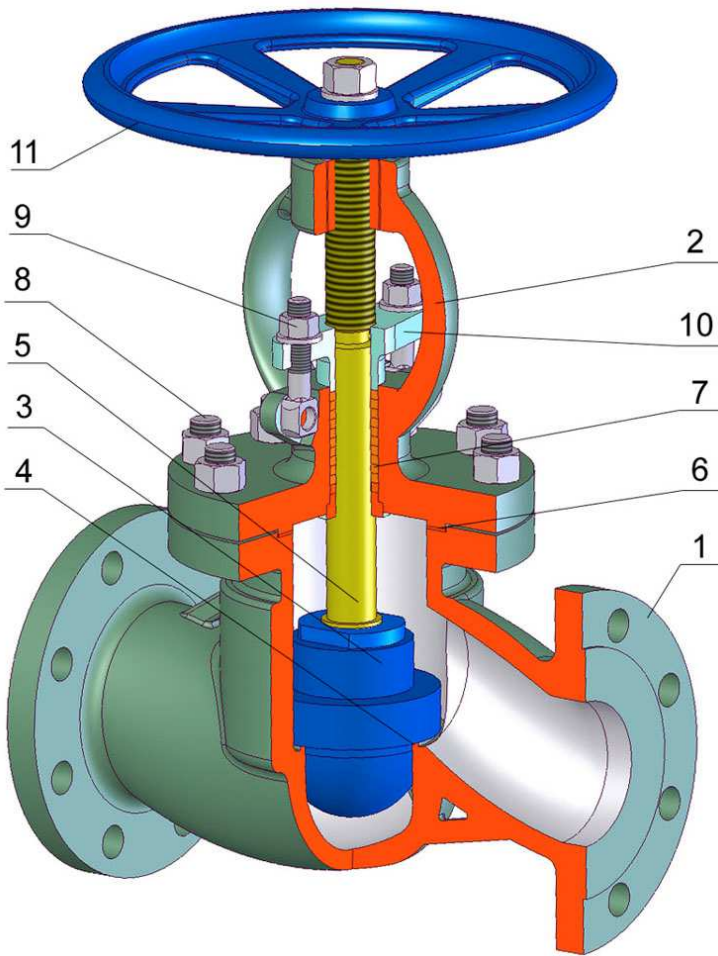

TYPE	V40
Nominal pressure/ номинальное давление	PN 16
Nominal size/ номинальный размер	DN 15 – 200

Design / конструкция	EN 13709
Flanges / фланцы	EN 1092-1
Welding end / концы под приварку	EN 12627
Face-to-face/ стр.длина	DIN 3202
Testing/ испытания	EN 12266-1
Pressure/Temperature Давление / Температура	EN 12516-1

Operation / управление	
1	Handwheel/ маховик
3	Electric actuator /электропривод
4	Pneumatic actuator /пнеупривод

		Trim		
		1	5	8
3	Wedge facing /уплотн.поверх.диска	13 Cr	Stellite 6	13 Cr
4	Seat facing /уплотн.поверх.седла	13Cr	Stellite 6	Stellite 6

Pos	Part / деталь	Material / материал			
		-29 - +400 °C	-20 - +593 °C	-47 - +340 °C	-70 - +350 °C
		DIN (ASTM)	DIN (ASTM)	DIN (ASTM)	DIN (ASTM)
1	Body / корпус	C22.8 (A105) GS-C25 (WCB)	13CrMo44 (F11) GS-17CrMo5-5 (WC6)	TSTE 355 (LF2) GS-20Mn5 (LCB)	X5CrNi18-9 (F304) GX5CrNi 18-9 (CF8)
2	Bonnet / крышка	C22.8(A105) GS-C25 (WCB)	13CrMo44(F11) GS-17CrMo5-5 (WC6)	TSTE 355 (LF2) GS-20Mn5 (LCB)	X5CrNi18-9(F304) GX5CrNi 18-9 (CF8)
3	Disc / диск	X10Cr13(410)/ weld-on	X10Cr13(410)/ weld-on	X5CrNi18-9(F304)/ weld-on	X5CrNi18-9(F304)/ weld-on
4	Seat /седло	X10Cr13 (410)+ weld-on	X10Cr13 (410)+ weld-on	X5CrNi18-9(F304)+ weld-on	X5CrNi18-9(F304)+ weld-on
5	Stem /пиндель	X10Cr13 (410)	X10Cr13 (410)	X5CrNi18-9(F304)	X5CrNi18-9(F304)
6	Sealing /уплотнение	Spiral-graphite/SS	Spiral-graphite/SS	Spiral-graphite/SS	Spiral-graphite/PTFE/SS
7	Packing / сальник	Graphite/PTFE	Graphite/PTFE	Graphite/PTFE	Graphite/PTFE
8	Bolt / болт	A193 B7	A193 B7	A182 L7	A193 B7
9	Nut / гайка	A194 2H	A194 2H	A194 8	A194 2H
10	Packing flange /фланец сальника	C22.8(A105)	X15Cr13(F6)	X15Cr13(F6)	X5CrNi18-9(F304)
11	Hand Wheel / маховик	Carbon steel	Carbon steel	Carbon steel	Carbon steel

Other material specification upon request / другое исполнение по заказу

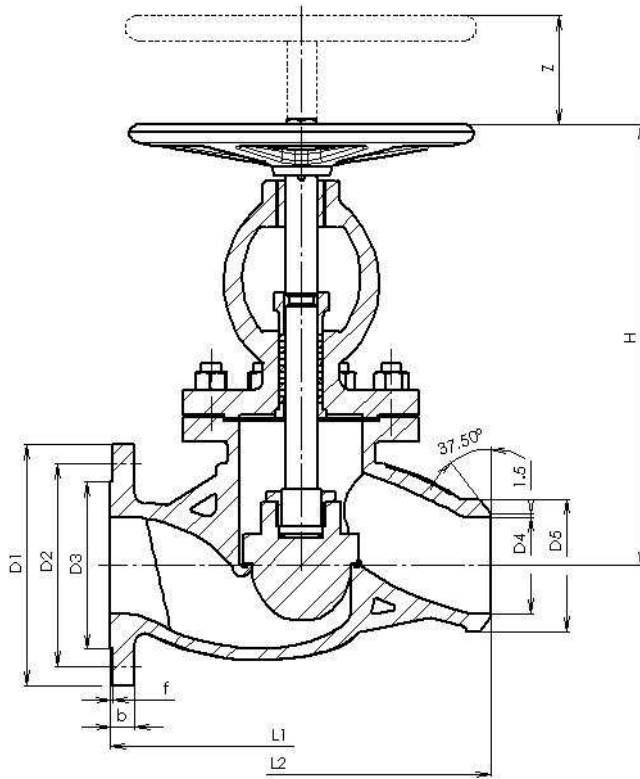

Main and connecting dimensions / главные и присоед. размеры												
DN	15	25	40	50	65	80	100	125	150	200		
D1	95	115	150	165	185	200	220	250	285	340		
D2	65	85	110	125	145	160	180	210	240	295		
D3	47	68	88	102	122	138	158	188	212	268		
D4	According to pipe schedule / согласно размеру трубы											
D5	21,3	33,4	48,3	60,3	73	88,9	114,3	141,3	168,3	219,1		
b	14	16	18	18	18	20	20	22	22	24		
f	2	2	2	2	2	2	2	2	2	2		
n	4	4	4	4	4*	8	8	8	8	12		
d	14	14	18	18	18	18	18	18	22	22		
bolt	M12	M12	M16	M16	M16	M16	M16	M16	M20	M20		
H	240	285	300	305	354	402	437	496	541	699		
L1	130	160	200	230	290	310	350	400	480	600		
L2	130	160	200	230	290	310	350	400	480	600		
z	12	18	19	21	26	34	38	54	61	75		
Dk	120	160	180	200	200	250	250	300	350	400		
m (kg)	8	12	17	20	30	38	56	75	100	182		

